

GEMM

BCB15USN



The BCB15US offers reliable high-volume blast chilling for professional kitchens. Its powerful cooling system quickly brings down the core temperature of food to safe levels while preserving freshness and taste.

FEATURES

- High-capacity blast chiller accomodating up to 15 GN 1/1 pans or full-size sheet pans.
- Now equipped with R290 refrigerant for reduced environmental impact.
- Offers multiple cycle styles, including gentle chilling, rapid chilling, and deep-freeze programs to suit different product types.
- Automatic defrost with pause function helps maintain stable performance and consistent airflow.
- Built with a full stainless steel interior and exterior for long-term durability.



PARTS AND LABOR



FOR COMPRESSOR

LED CONTROL PANEL



SPECIFICATIONS

Power: 230 V ~ 60 Hz

Max. absorbed power: 10 A

Compressor power: (2) 1 1/4 HP

Total volume capacity: 339 qt. (321 L)

Tray capacity: 15 pans (not included)

Pitch: 2.6" (67 mm)

Refrigerant gas: R290

Climate class: 5

Output:

81.5 lb (149 °F ÷ +37 °F)

53 lb (149 °F ÷ 0 °F)

Chamber temperature: 203/-40 °F

Chilling capacity: in 90 mins

197 °F to 37 °F = 154 lb

(90 °C to 3 °C = 70 kg)

Freezing capacity: in 240 mins

197 °F to 0 °F = 132 lbs

(90 °C to -18 °C = 60 kg)

Dimensions:

Length: 34.6" (87 cm)

Width: 33.9" (86 cm)

Height: 74.8" (189 cm)

Connection:



(230 V)

Net weight: 500 lb (226 kg)

Included accessories

- Probe



Intertek



Intertek

GEMM
BCB15USN

FRONTAL VIEW

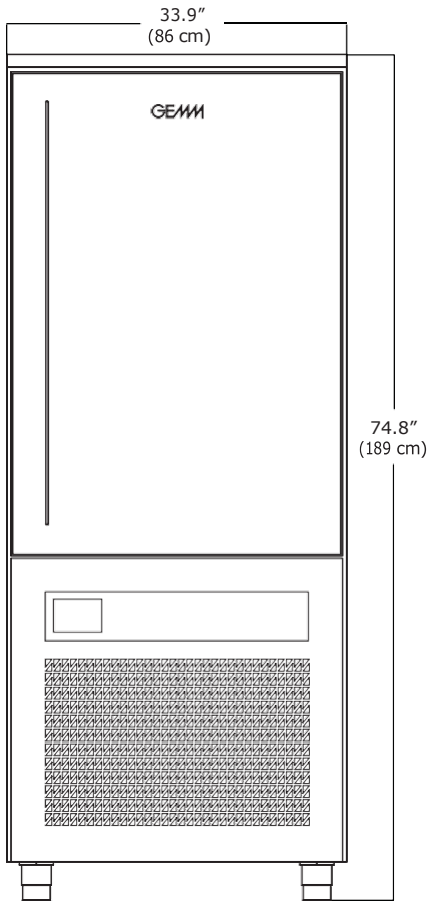

TOP VIEW

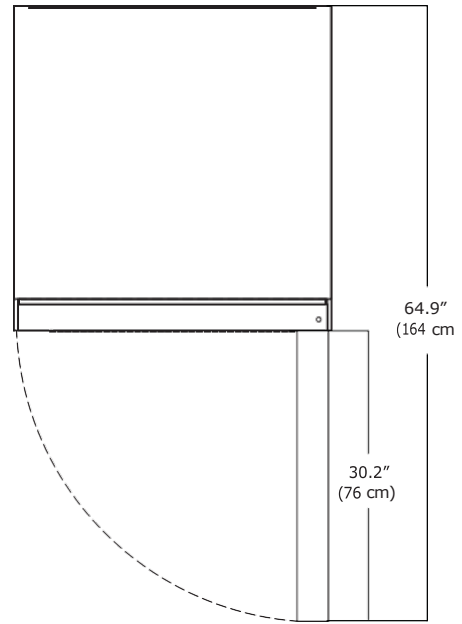

LEFT VIEW

