



193
SP P

The ultimate pump-fed counter top model for high volume production with heat treatment.



Performance and Quality The Carpigiani reputation for the smoothest, creamiest soft serve in the market is proven with this powerful, customizable model for two flavors and twist flavor. Spigot flow allows for adjustable product flow. Hard-O-Tronic consistency control technology Exclusive patented system that regulates refrigeration by measuring product viscosity to maintain consistent quality control. The Optional Star Door allows you to use different nozzles to create unique shapes and monoportion products.



Convenience Hopper agitator prevents mixture separation and maintains consistent refrigerated temperature. Audible Signal alerts when refill is needed. Product is fed from rear of cylinder eliminating need to prime and allowing more controllable overrun of up to 80% on pump models.



Savings Lowest power consumption and the least number of components to clean compared to similar models in the industry. Unique cylinder construction delivers better results using less electricity.



Safety TEOREMA guarantees facilitated assistance by providing on-line monitoring and diagnosis on a tablet, phone or PC wherever you are.



Hygiene Standby mode maintains safe product temperatures in the freezing cylinder and mix hopper utilizing minimal energy during long no-use periods. Our automatic heat treatment system makes it possible to set the automatic heat treatment at a maximum interval of 42 days. *Always check with your Local Health inspector as cleaning requirements may vary.



*request the kits from your distributor to maintain your machine hygienically clean.

carpigiani.com/us

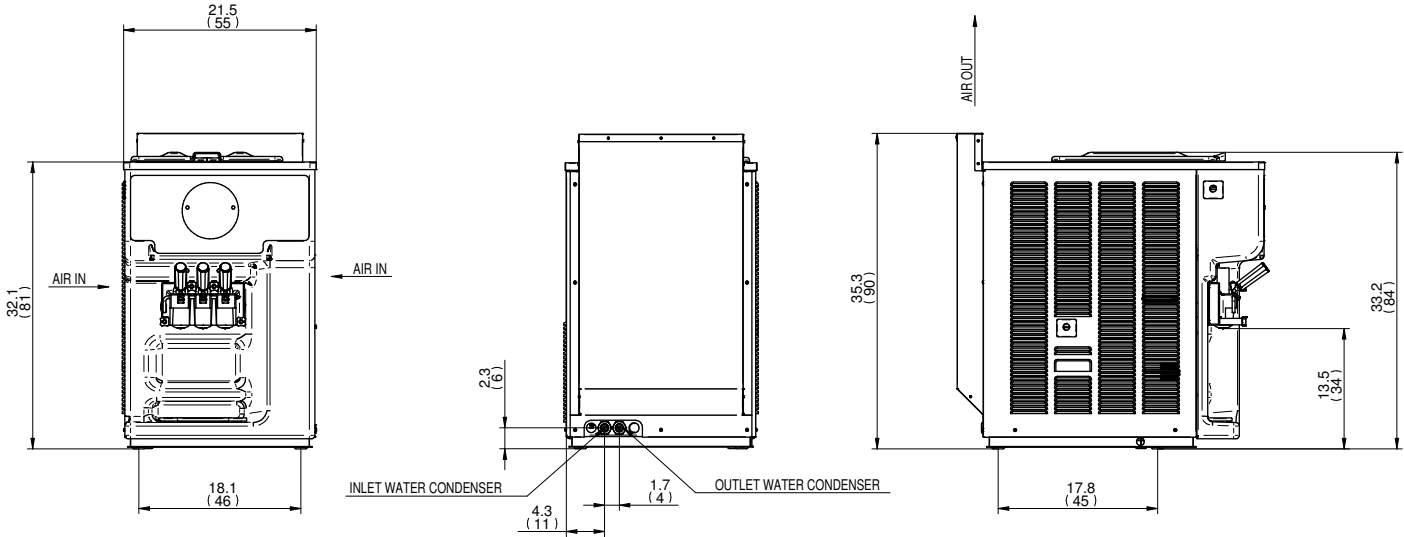

	WATER		AIR	
Weights	lbs.	kgs.	lbs.	kgs.
Net	463	210	463	210
Crated	509	231	540	245
	cu. ft.	cu. m.	cu. ft.	cu. m.
Volume	30.37	0.86	29.31	0.83
Dimensions	in.	cm.	in.	cm.
Width	21.5	55	21.5	55
Depth	34.4	88	34.4	88
Height	35.3	90	35.3	90
Electrical	Maximum Fuse Size	Minimum Circuit Ampacity	Poles (P) Wires (W)	
208-230/60/1 Air	50A	40A	1P, 1W	
208-230/60/3 Air	30A	30A	3P, 3W	

Specifications

Electrical

A dedicated electrical connection is required. Manufactured to be permanently connected. See the Electrical chart for the proper electrical requirements. Consult your local Carpigiani distributor for cord & receptacle specifications as local codes allow.

Beater Motor

1,2 HP + 1,2 HP

Refrigeration System

R449A

Water Cooled

Water inlets and drain connections in the rear 1/2" MPT

Air Cooled *

Minimum clearance: 3" (8 cm) on both side panels and 0" (0 cm) from the rear panel for proper air circulation.

Hopper Capacity

13 quarts (12 liters)

All specifications mentioned must be considered approximate; Carpigiani reserves the right to modify, without notice, all parts deemed necessary. This unit may be manufactured in other electrical characteristics and may have additional regulatory agency approvals, please consult the local Carpigiani Distributor. Check name plate for exact electrical data. * Room temperature 68 °F (20 °C).

Bidding Specs

Electrical Volt _____ Hz _____ Ph _____ Neutral Yes No Cooling Air Water

Options _____



738 Gallimore Dairy Road, Suite 113
High Point, NC - 27265
Toll free (800) 648 4389



Dealer

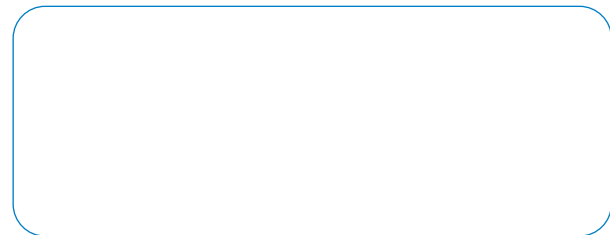

www.bipiuci.it | printed 01/2023

an Ali Group Company



The Spirit of Excellence