



Blender and
Homogenizer



Ideal for preparing
Homemade Ice Cream Mix
And much more...



Turbomix



Turbomix

The **Carpigiani Turbomix** is an indispensable instrument for preparing all sorts of mixes in the modern ice cream parlor. It can be used to whisk, blend, emulsify, break-up dry or fibrous ingredients and separate greases in liquids, in order to obtain perfectly homogeneous ice cream mixes. Besides having the ability to prepare homemade ice cream mixes, it is also very useful in making confectionery products. It can be used to blend and emulsify thick products, producing many other foodstuffs; as well as materials used in the chemical, pharmaceutical and cosmetics sectors. The blender has a stable, vertical structure upon which the motor support arm is fixed. It has a powerful variable-speed motor, with vertical and oscillating movement; two different emulsifiers, a cutter and an optional steel bucket.



Cream Emulsifier

The ideal stirrer for breaking up classic pastry cream, which may be oily or dense and sugary, into the base mix. The high-speed rotation and shape of the rotor facilitate the speedy emulsification of the pastries, bringing out the best fragrance and creamiest flavour.



Fruit Emulsifier

Ideal for chopping and mixing pieces of fresh or frozen fruit and blending fruit puree into the base. Useful for mixing powders, such as sugars and cold stabilizers, to prepare water-based mixes.



Optional Cutter

A rotary blender able to chop significantly large pieces of fruit, such as whole pears and apples. It works perfectly when used with emulsifiers to transform blended fruit into a fine, easy-to-mix puree.

Handling times

To blend and emulsify classic pastries into the base mix approximately 30 seconds for 1.32 gal (5 liters).
To dissolve the mix in cold milk or water, for a guaranteed quality ice cream, approx 60 seconds for 1.32 gal (5 liters).
To produce a complete perfectly emulsified mix from single ingredients for a customized ice cream, approx 120 seconds for 1.32 gal (5 liters).



Tomato sauce



Mayonnaise



Guacamole - Avocado

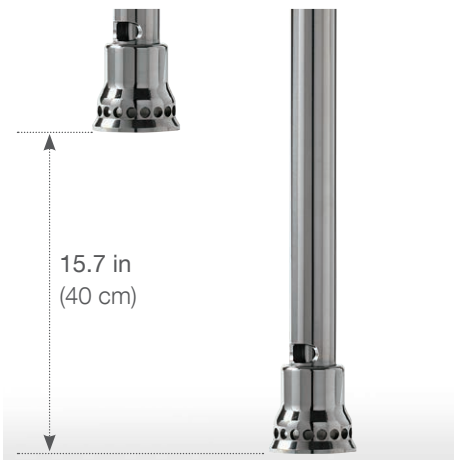

Vertical Travel

In order to blend and emulsify different quantities of mix, the Turbomix has a vertical travel of almost 15.7 in (40 cm). This vertical movement is assisted by a weighted system, which makes it easy to move the motor up or down. It is possible to block the motor arm at the desired height, using the appropriate knob.



Horizontal Oscillation

The Turbomix can be moved in circles, by guiding the motor with the handles, in order to allow the emulsifier turbine to absorb the solid ingredients that tend to stick to the sides of the bucket. This horizontal oscillation has a maximum diameter of nearly 9.8 in (25 cm).



Control Panel

This controls all functions of the Turbomix; the on/off button, the timer to program the blending time, and the led bar to control the motor speed. The emergency button stops the machine immediately upon being pressed.

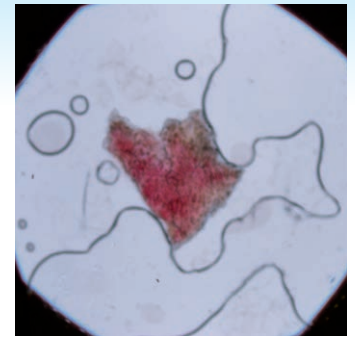

2-Handed Control

For maximum work safety, the Turbomix only runs when the operator has both hands on the control handles. When the machine is on, it is put into motion by the simultaneous presence of the hands on the handles; it is possible to adjust the speed by placing one's thumbs on the handles controls. After 10 seconds of continuous contact of the hands on the handles, the machine beeps and a bright light switches itself on, indicating that the machine can now operate automatically.

At this point you can remove your hands from the handles. The machine will finish the program set automatically and the operator will be able to focus on other activities.

Carpi Care kit



Carpi Care kit: request it from your dealer to always keep your machine hygienically perfect.

Features of the Turbomix 10

Motor RPM	3.000 - 12.000
Rotor Speed	approx 22 m/sec
Minimum Quantity per Cycle	0.79 gal (3 liters)
Maximum Quantity per Cycle	3.96 gal (15 liters)
Electric Power	Volt 208-240 / Hz 60 / Ph 1
Max Fuse Size / Amps	10
Dimensions W x D x H (min.)	in 17.3 x 19.7 x 29.9 (cm 44 x 50 x 76)
Dimensions W x D x H (max)	in 17.3 x 19.7 x 44.9 (cm 44 x 50 x 114)
Weight	lb 143.3 (kg 65)

Specifications are approximate. Carpigiani reserves the right to make changes without notice.

Turbomix is made by Carpigiani according to a Certified Quality System UNI ENI ISO 9001.

Changing Emulsifiers

It is possible to pull out and change the emulsifier by unscrewing the ring nut under the motor. The piece between the motor and rotor is plastic, making it easy to replace and also protecting the machine in case of improper use. At the end of a day's work, the used emulsifiers must be completely dismantled and cleaned.

Apple particle after emulsion with cream emulsifier

Test results have shown that the use of the cutter, the fruit emulsifier and the cream emulsifier in sequence have progressively reduced the dimensions of the red apple peel down to a unique thinness visible only by microscope (4x magnification).

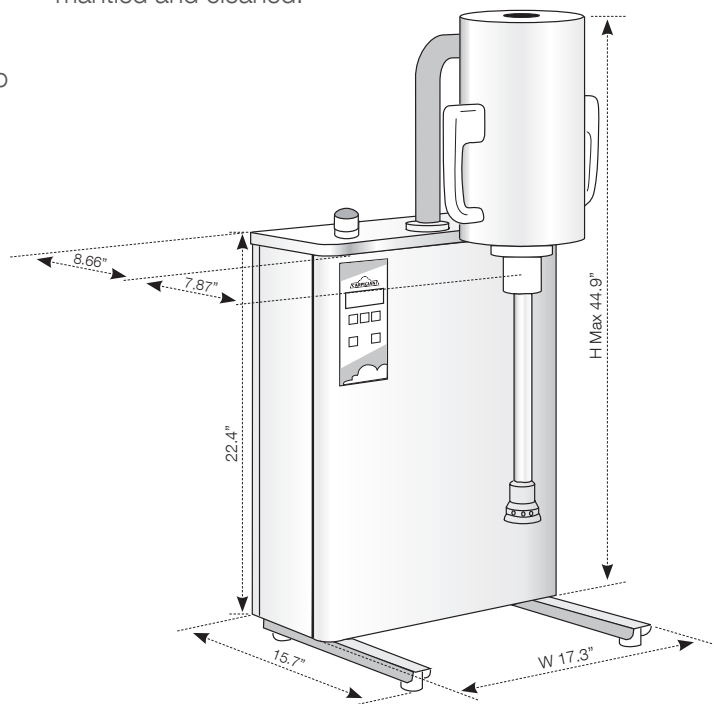

738 Gallimore Dairy Road, Suite 113
High Point, NC - 27265
Toll free (800) 648 4389



Dealer

an Ali Group Company



The Spirit of Excellence