



Synthesis 2

Horizontal

Innovative system of modular units to make Ice Cream in front of customers.



Performance and Quality All-in-one modular units to Mix, Heat, Batch Freeze, Serve and Store Ice Cream, Gelato and Sorbets right in front of customers. This is an innovative approach to Frozen Desserts, freshly made Ice Cream is ready to serve right away. Each unit has of two independent cylinders with Hard-O-Tronic exclusive system for excellent Ice Cream or Gelato. The status of the Batch freezing cycle is constantly displayed on the LCD display.



Convenience With Advanced refill, the operator can refill the cylinder with a needed quantity of liquid mix & restart the batch freezing cycle even when only a small quantity of product is left in the cylinder. The LCD display allows the operator to know the operational status of each cylinder. During the batch freezing process, the screen will show 1. Active Program; 2. Current consistency; 3. Final consistency (modifiable) 4. Modifiable storage temperature; 5. Agitator speed (modifiable).



Savings All-in-one machine puts the entire Ice Cream making process in one unit.



Safety Each cylinder has its own consistency and storage temperature settings to best produce every single flavor. Customers can see the flavors being made through the thermoplastic lid. While closed, the lid protects the refrigerated scooper.



Hygiene The unique beater design was created to easily serve the Ice Cream. The beater with a lowered central shaft is equipped with 2 interchangeable self-adjusting scraping blades, ideal for constant cleaning and cylinder performance. Heated cleaning Hot Wash function speeds up the cleaning process by heating the cylinder to dissolve any product residues. Dry Clean, removes any residual wetness or humidity from the cylinder after cleaning. Each unit is equipped with a wash kit consisting of a handheld shower and liquid aspirator with an integrated pump and filter.



Carpi Care kit

Carpi Clean kit*



*request the kits from your distributor to maintain your machine hygienically clean.

carpigiani.com/us

Synthesis 2 Horizontal

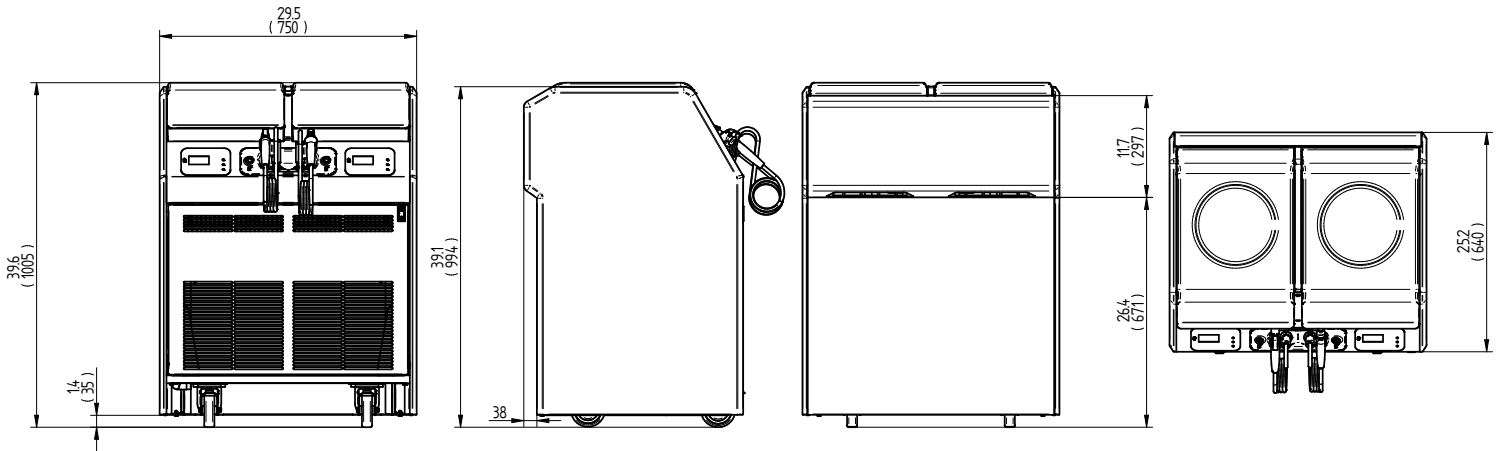

AIR

Weights	lbs.	kgs.	
Net	432	196	
Crated	440	200	
cu. ft.		cu. m.	
Volume	25.78	0.73	
Dimensions	in.	cm.	
Width	29.5	75	
Depth	25.6	65	
Height	39.4	100	
Electrical	Maximum Fuse Size	Minimum Circuit Ampacity	Poles (P) Wires (W)
220/60/1 Air	13A	13A	1P, 1W

Specifications

Electrical

A dedicated electrical connection is required. Manufactured to be permanently connected. See the Electrical chart for the proper electrical requirements. Consult your local Carpigiani distributor for cord & receptacle specifications as local codes allow.

Beater Motors

0,5 + 0,5 HP

Refrigeration System

R449A

Air Cooled *

Minimum clearance: 0" (0 cm) on both side panels and 0" (0 cm) from the rear panel for proper air circulation.

Cylinder Capacity

6.34 quarts (6 liters)

All specifications mentioned must be considered approximate; Carpigiani reserves the right to modify, without notice, all parts deemed necessary. This unit may be manufactured in other electrical characteristics and may have additional regulatory agency approvals, please consult the local Carpigiani Distributor. Check name plate for exact electrical data. * Room temperature 68 °F (20 °C).

Bidding Specs

Electrical Volt _____ Hz _____ Ph _____ Neutral Yes No Cooling Air Water

Options _____



738 Gallimore Dairy Road, Suite 113
High Point, NC - 27265
Toll free (800) 648 4389



Dealer

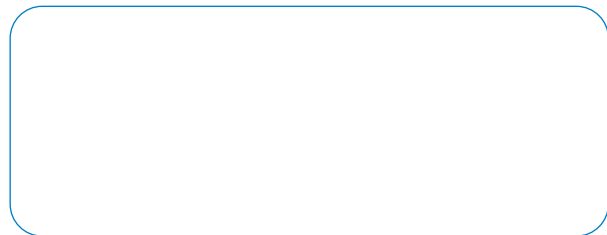

www.bipiuci.it | printed 03/2023

an Ali Group Company



The Spirit of Excellence